

SCREEN

Creating a Future in Print

# Truepress Jet520 HD

Full-Color Variable Printing System

See for yourself,  
The quality that brings new possibilities



# CHALLENGING

## Quality that opens new doors

Capitalizing on the quality, speed, accuracy, and innovation in inkjet printing, we are continually evolving the Truepress Jet520 series printing. Each new development advances our pursuit for quality that expands the boundaries of conventional inkjet concepts, taking inkjet printing to levels never previously seen.



# Truepress Jet520 HD

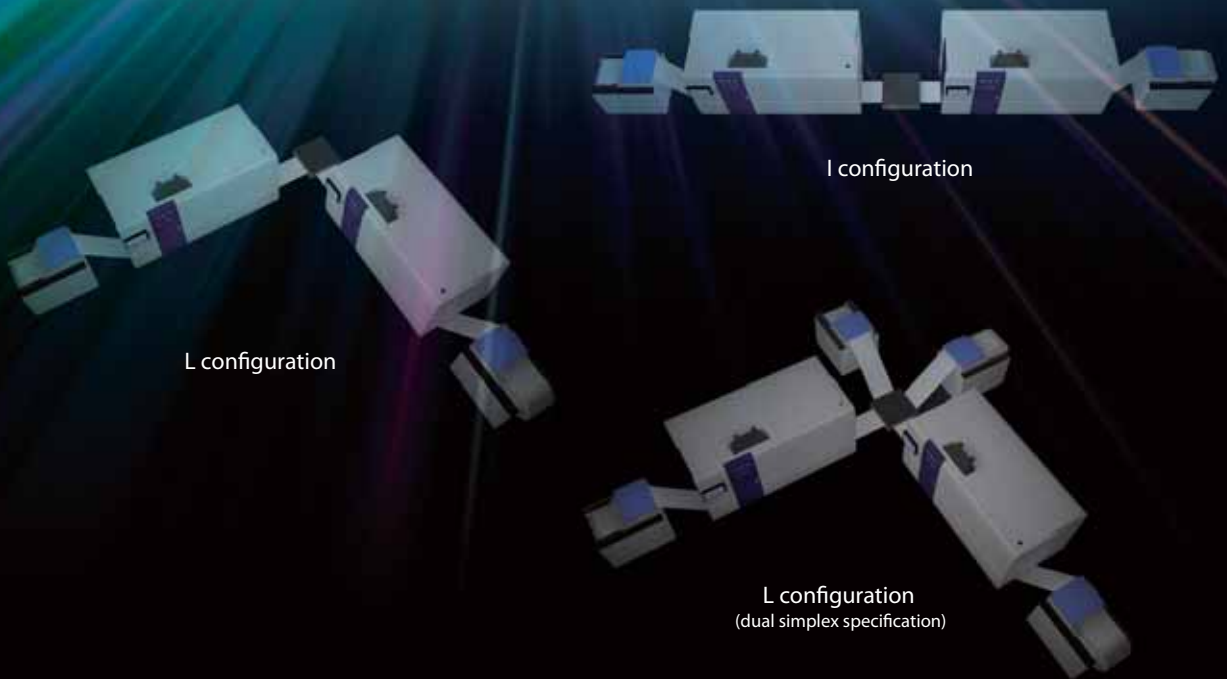

# Breathtaking

A B C D **E** F G H I J K L M N O P Q R S T U V W X Y Z



Truepress Jet320

### Colour management

A real strength of Equios is its integrated suite of Colour Management tools. This means that it is easy to create colour matches across all of your different output devices ensuring the best possible quality is produced at all times. Equios Online is another important feature as this allows your customers to give their proofing comments via a standard web browser - speeding up production and avoiding misunderstandings that can easily arise from marked up hard copy proofs.

### Fully integrated production

Book production has become increasingly automated over recent years as printers have strived to reduce the labour element of manufacturing. This is particularly true for digital where small volumes would be uneconomic if manual stages could not be eliminated. Screen has launched its Equiosnet partnership

Screen has been creating technology for printing colour or more than years



GUIDE TO THE ANIMAL KINGDOM

programme as a way of facilitating the easy integration of many different production processes. Integration is based on the industry standard JDF/JMF protocols and this means that Equios can communicate with a huge variety of prepress, printing and finishing devices. For a full list of the Equiosnet partners, visit [www.screen.co.jp/equiosnetpartners](http://www.screen.co.jp/equiosnetpartners)

### Computer to plate - the heart of litho production



For many industry experts computer to plate (CTP) marked the biggest single transformation in print production. Today's inkjet presses may seriously challenge that view but nonetheless the disappearance of thousands of film platters and print down frames changed printing dramatically. Screen has long been the market leader in CTP and this is a position it maintains. The most recent announcements mean that Screen can supply devices that are capable of outputting plates for every press size from 62 up to the new super-size 48 page web offset presses.

### High-speed inkjet - setting new standards for digital production

Digital printing was introduced to book (more) printing in the early 1990s and the value of short-run production was gradually recognized by publishers as a way of increasing profitability through reduced capital committed to warehouses full of unsold books. It also enabled small quantities of slower selling titles to be produced as they were required so no title ever had to be out of stock. As digital technology developed, so did publishing concepts that took advantage of the opportunity to produce customized projects using repurposed data for different market sectors. These projects were initially restricted to monochrome books but the more recent introduction of high speed inkjet presses has led to an extension of this publishing opportunity to colour books. Screen launched the first colour capable continuous feed inkjet press



# Realistic images that jump off the page Truepress Jet520HD brings color to life

The Truepress Jet520HD takes inkjet to a completely different level, vividly reproducing images, textures, details and solid areas of color in a way not previously seen from high-speed inkjet printing.

## Featuring grayscale printing and the latest printhead technology

With its 1,200 dpi high-resolution and precise droplet size control, the Truepress Jet520HD delivers high-quality printing even in areas with the most minute of details. Thanks to its beautifully smooth and vibrant reproduction of these details, the Truepress Jet520HD produces quality levels that match offset printing.

*Gradations will vary according to the resolution.*

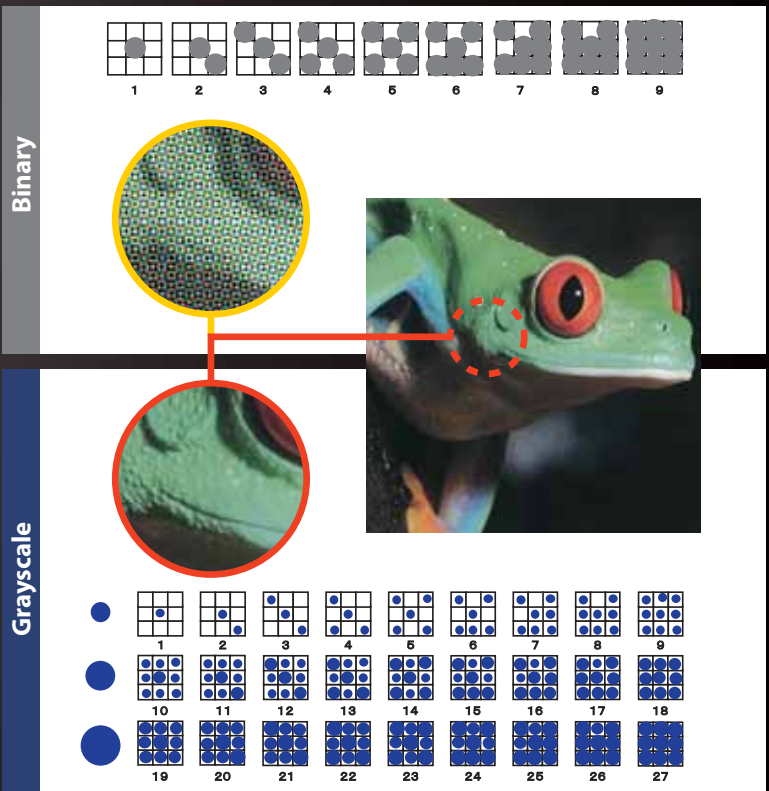

# Beautiful detail and stunning color for unlimited applications

Books, direct mail, brochures and short-run magazines  
— the image reproduction on the Truepress Jet520HD gives stunning results  
for every application on a wide range of papers.

## High-density pigment inks (newly developed)

Truepress inks for the 520HD make it possible to reproduce a color gamut that rivals offset printing using CMYK inks. This delivers truly impressive photo-quality output that can not be achieved with existing high speed printer in this industry.

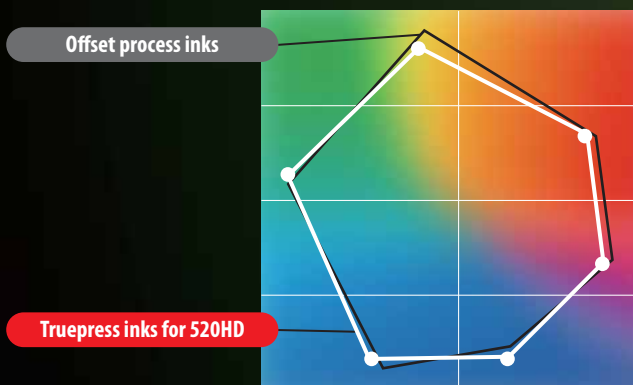

*Inspiring*

Mont-Saint-Michel

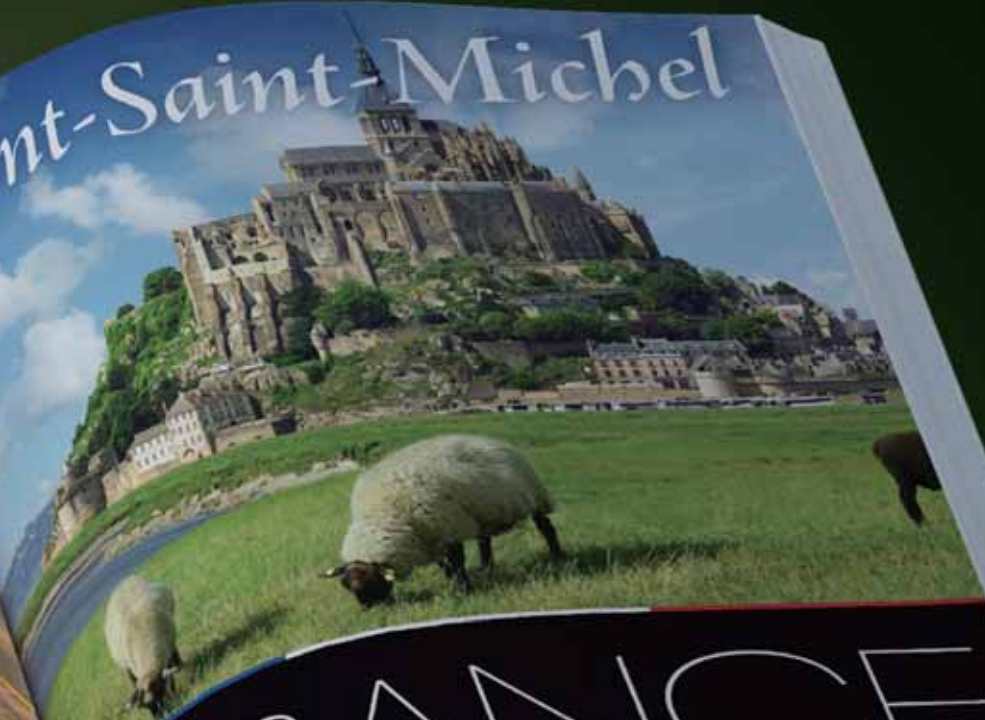

FRANCE



Louvre Museum



# Gorgeously Detailed

The Art of Time  
Watch Collection 2014





# Astounding technology that fully expresses even detailed areas

The Truepress Jet520HD delivers quality levels that dramatically exceed expectations even during high-speed printing. This includes extremely accurate reproduction of the microtext used in security printing.



## Accurately reproduces nano-images

The Truepress Jet520HD is able to accurately place 2 picoliter droplets, the smallest size currently available, on paper as it moves through a high-speed transfer system. This extremely accurate printing is made possible by the system's new printhead technology. Even microtext embedded in lines and patterns is reproduced with unflinching precision.



# The optimum added value that is most appropriate to the task

Even with variable printing, the Truepress Jet520HD takes print quality to a completely new level. Every leaflet or flyer reaches its target with quality levels that rival offset printing.

## Ultra-high performance RIP

The Truepress Jet520HD is designed to produce high-speed variable printing of outstanding quality. EQUIOS's smart variable data processing function works with Mercury RIP Architecture, enabling RIP processing for variable printing of rich content images with no loss of speed.



# Distinctive

Ms. Mary Smith

No. 00183911

1484 S. Eagle Flight Way Boise, ID 83709, U.S.A.

## Autumn Campaign Special!

Saturday, Nov. 15, 2014 - Sunday, Dec. 14, 2014

**Autumn Double Campaign** ✪✪  
Use a 10% discount coupon during the campaign period to make a purchase and you'll get "Beauty Nature" for free - a brand new product that won the "Best Cosmetics" award in 2014. Beauty Nature uses the latest "ink-drop technology" to bring out an impressive look that spreads out from deep within your skin, giving your skin a naturally shiny and clear look. Don't miss this chance to give your skin the subtly captivating and totally natural look that it deserves!

Make a purchase during the campaign period and get a free "Shimmer Clearing Balm" that includes a rich berry gel face cream.



Mary Smith, We've Got Wonderful News For You!

### 10% OFF

CAMPAIGN PERIOD Saturday, Nov. 15, 2014 - Sunday, Dec. 14, 2014  
Bring this flyer to our store for a 10% discount on one of the products listed on the cover.

This offer may not be valid in conjunction with other campaigns for the same products.



1484 S. Eagle Flight Way Boise, ID 83709, U.S.A.

Ms. Maria Miller

No. 00183911

1484 S. Eagle Flight Way Boise, ID 83709, U.S.A.

## Autumn Campaign Special!

Saturday, Nov. 15, 2014 - Sunday, Dec. 14, 2014

## Autumn Campaign Special

Saturday, Nov. 15, 2014 - Sunday, Dec. 14, 2014

**Autumn Double Campaign** ✪✪  
Use a 30% discount coupon during the campaign period to make a purchase and you'll get "Beauty Nature" for free - a brand new product that won the "Best Cosmetics" award in 2014. Beauty Nature uses the latest "ink-drop technology" to bring out an impressive look that spreads out from deep within your skin, giving your skin a naturally shiny and clear look. Don't miss this chance to give your skin the subtly captivating and totally natural look that it deserves!

Make a purchase during the campaign period and get the "New Vogue" cosmetic set - perfect for that fiery winter makeup look that's popular this autumn!



Maria Miller, We've Got Wonderful News For You!

### 30% OFF

CAMPAIGN PERIOD Saturday, Nov. 15, 2014 - Sunday, Dec. 14, 2014  
Bring this flyer to our store for a 30% discount on one of the products listed on the cover.

This offer may not be valid in conjunction with other campaigns for the same products.



# HARDWARE PERFORMANCE

The Truepress Jet520HD incorporates a range of leading technologies in its printhead, ink and transport systems, all designed to maximize its capabilities and produce quality levels that rival offset printing. This outstanding performance redefines the existing concept of variable printing systems and opens up new business opportunities in the printing market.

## PRINT QUALITY

### ▶ Maximum resolution of 1,200 dpi

The adoption of newly developed grayscale heads allows multi-droplet printing at a resolution of 1,200 dpi. This enables extremely high-quality output of the gradations for middletones, supporting smooth color reproduction with minimal graininess.

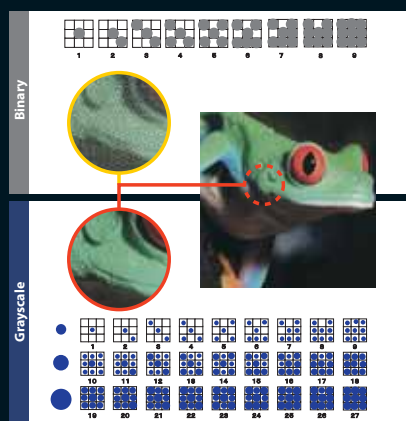

### ▶ Precise 0.1 pt lines and microtext

Conventional inkjet presses are known for their issues with printing microtext and fine lines. Thanks to its maximum resolution of 1,200 dpi and minimum droplet size of two picoliters, the Truepress Jet520HD delivers extremely precise reproduction even in this range. The result is a sharp, eye-catching finish with no spread of ink or jaggies.

Printing result of 2 pt characters

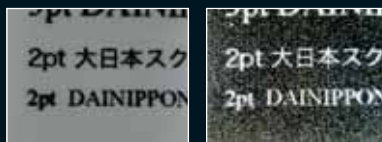

Printing result of 0.1 pt lines



### ▶ Quality control using built-in scanner

Density difference between printheads is often cited as a problem when using presses with multiple heads. The Truepress Jet520HD features built-in quality control scanners that perform regular checks and automatically adjust uniformity. After correction, the information is registered as an individual paper profile.



## INK AND HEAD CONTROL

### ▶ High-performance specialized inks

SCREEN has developed a range of new inks with various properties including water, heat, light and chemical resistance. With a wide color gamut virtually the same as offset inks, SCREEN's proprietary inks enable unprecedented quality levels for an inkjet press.

Comparison of color gamuts

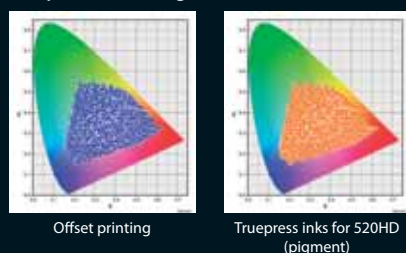

### ▶ Two additional printheads

An extra two printheads can be added as options (planned), allowing the Truepress Jet520HD to accommodate specialized inks such as spot colors and protective coats, in addition to CMYK (up to six colors). The wider expressive capabilities provided by these inks greatly expand the range of printing services that can be offered to clients.



### ▶ Smart printhead control

The Truepress Jet520HD is equipped with a unique printhead control that recognizes the colors included in print data in advance and activates only the required heads. The printheads that are not in use keep the cartridge caps closed, increasing the efficiency of both ink and energy usage.



## VARIOUS CAPABILITIES

### ► Easy touch panel operation

The entire sequence of operations from job registration to printing can all be entered and checked from the touch panel. This includes advance registration of paper information and fine adjustments to settings. Touch panel control helps to maximize both on-site work efficiency and up-time.



Basic information



Layout

### ► Compatibility with various paper types

The Truepress Jet520HD comes preinstalled with drum heaters and five air heating units. Either drying method can be selected to suit the paper type. It also incorporates a four axis mechanism that enables stable transfer of a wide variety of paper types.

Together these features provide rapid, high-quality printing on standard inkjet papers as well as recycled and special papers with a variety of characteristics. The Truepress Jet520HD also supports paper thicknesses from 40 to 250 gsm, significantly expanding the range of potential applications.



### ► Dynamic Nozzle Shift (DNS)

The Truepress Jet520HD is equipped with the Dynamic Nozzle Shift mechanism. The sensors installed as part of this mechanism perform real-time detection of the oscillations that occur during the high-speed transport of paper. The printing position is then automatically adjusted to the optimal location for the printing data. The mechanism reduces the effects of meandering and skewing much more effectively than in previous systems and ensures stable, consistent print quality.

### ► Cooling roller

The cooling roller normalizes paper that has lengthened while passing through the drying unit of the first printer (front side). This helps to maintain registration accuracy between the front and back surfaces in the second printer (back side). It also prevents heat transfer to the back side printer by the paper and supports stable control and maintenance of the equipment.

### ► Paper feeding assist mechanism

Once the leading edge of the paper is fixed by the paper feeding assist bar, it can be quickly and reliably sent through to the discharge section simply by turning a handle. The stability of this process eliminates paper feeding errors and greatly reduces the labor involved in preparing for printing.



### ► Easy maintenance

The Truepress Jet520HD uses a pull-out type printhead module, allowing daily maintenance to be performed with minimum effort. In the unlikely event a problem does occur, support staff can handle the situation more quickly, helping to maintain high operating ratios.



### ► Safe and reliable ink replacement

The ergonomically designed ink supply system uses 10 liter ink cartridges that can easily be handled by any operator. These cartridges also feature a different cap shape for each color to prevent incorrect insertion. The cartridges also automatically tilt as the remaining volume of ink decreases.



Two 10 liter ink cartridges can be set for each color.

# ADVANCED WORKFLOW

## Preloaded with main imposition templates

In addition to a full range of binding specifications for saddle-stitching, perfect binding and other formats, the Truepress Jet520HD comes preloaded with imposition templates optimized for the main folding patterns used for on-demand books, direct mail and various sheet formats as a standard feature.

Print jobs can now be created in a few simple steps. The control marks and bar codes required for postpress in digital printing can also be set with ease, supporting the creation of imposition layouts.

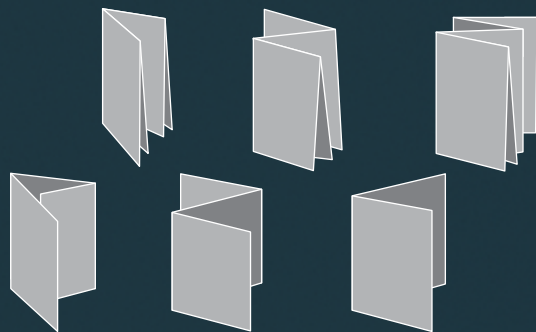

## EQUIOS Version 3



EQUIOS is a universal workflow system that draws on SCREEN's extensive prepress and printing knowledge to maximize the performance of our cutting-edge inkjet technology. EQUIOS offers high-speed processing using Adobe's PDF Print Engine 3 and Mercury RIP Architecture, a newly developed color management system that links to paper information and user-friendly imposition functions that integrate SCREEN's full prepress knowhow.

These features have been developed based on SCREEN's rich experience and encompass the full range of our professional knowledge. Together they help to provide a work environment that is easy to use regardless of the operator's own skill level.



The Mercury RIP Architecture is a scalability framework and distributed multi-tier cache technology developed by Adobe for its PDF Print Engine. Mercury enables enhanced, high-performance rendering and is essential for digital presses as well as variable printing. The EQUIOS workflow system for the Truepress Jet520HD incorporates this advanced RIP architecture.

## Ultra-fast RIPing of high-volume data

For web press printing, the computation speed of output data is an important factor that affects the operating ratio of the printing system in various ways. EQUIOS's smart variable data processing function minimizes the load placed on RIP processing by calculating the requirements for shared sections on each page once and then cashing them for reuse. Even with high-volume variable data and high-resolution images, print quality can be maintained without any loss of productivity.

## Automatic selection of optimum color profile

The EQUIOS Color Management System first converts all the elements in a job to the targeted color space, such as Japan Color, G7, or FOGRA. It then automatically selects the appropriate ICC profile according to paper types and output devices. Thanks to the EQUIOS Color Management System, specialized skills are not required to achieve professional results.

## Proprietary high-definition screening

The Truepress Jet520HD utilizes SCREEN's proprietary screening technology, enabling optimal display of gradations in images from highlights and shadows through to middletones. This system also minimizes moire and broken lines to produce high-definition output.

## Spot color editor

This editor allows spot colors to be selected from "spot color list" and printed as a patch before adjustment. Once a chart has been printed, the desired approximate color can be selected on the monitor synchronized with the chart and registered as a spot color (proxy color) profile. This data is automatically selected in subsequent jobs and any spot colors included in input data can be processed as the registered colors.

# PERFECT INSPECTION

## Original built-in design

The Truepress Jet520HD is equipped with JetInspection, its own specially designed, dedicated inspection system. JetInspection can be controlled directly from the operation panel of the Truepress Jet520HD. Even during printing, the operator is alerted by a warning light if any defects are detected and images of the defects and their positions can be checked in real-time via the operation panel and network. It is also possible to automatically create files for defect image data and link to postpress using printouts and CSV files.

## Superior defect detection function

Inspection is highly detailed. It is possible to detect everything from OCR fonts, decoded bar codes and missing dots to foreign substances, color variations and improperly output text.

Defects are displayed in an inspection results screen, making it easy for operators to spot them. Operators can also register printing data and the base color of the paper in advance. This helps prevent false positives and improves the accuracy of defect detection.

## Dual simplex inspection

In a dual simplex configuration, the two printers usually used for the front and back sides can both be operated independently as front side printers. With this configuration, it is possible to perform separate inspections for each printer.

# JetInspection

As print quality has continued to increase, calls for improved detection capabilities have also grown.

The Truepress Jet520HD is preloaded with JetInspection, software that is capable of performing highly comprehensive real-time inspection of high-quality variable images across all pages, in addition to of course providing conventional processing of OCR fonts and decoding of bar codes.

As well as significantly reducing cost and time requirements, JetInspection supports the development of new printing applications.

## Integration with conventional processing

When performing conventional overprinting, if the printing data is first captured via camera and preregistered, it can also be used during inspection of the overprinting. This allows the advance detection and specification of various problems that often escaped conventional inspection, including marking and inclusion of foreign particles in the paper of the initial printing.

## Secure workflow linked with EQUIOS

Linking with EQUIOS maximizes the performance of the Truepress Jet520HD and helps to achieve more consistent, accurate and worry-free production. It also enables inspection logs to be shared with EQUIOS.

Inspection records including defect information, OCR text, and the results of decoding barcodes are sent back to the EQUIOS print management system, where they can be saved as logs.

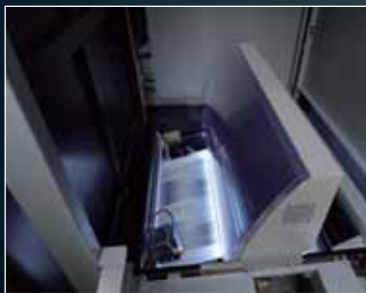

## Space requirements

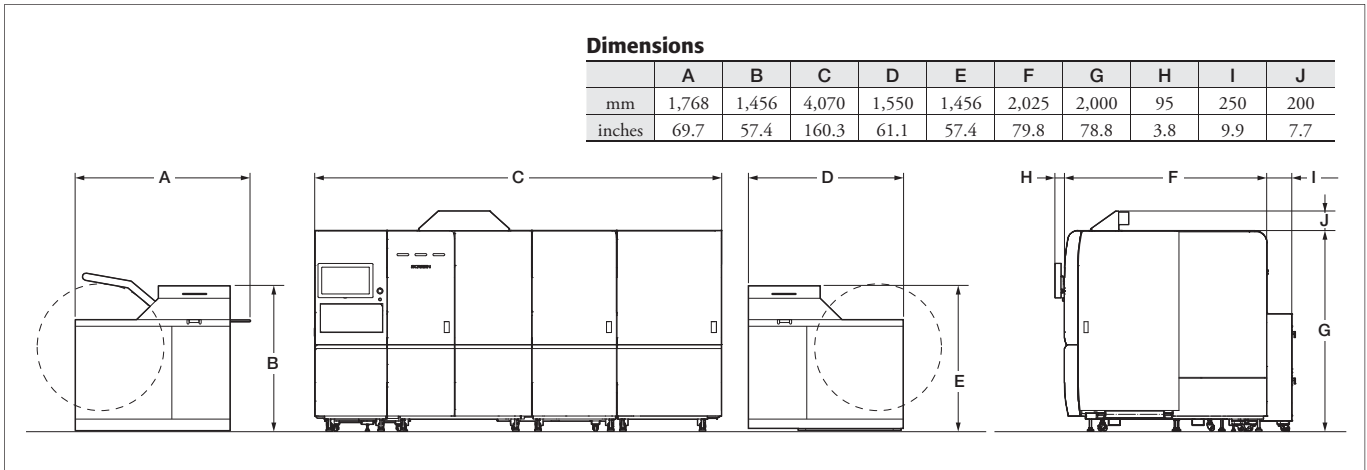

## Truepress Jet520HD specifications

Printing system	Inkjet, Piezo single-pass DOD
RIP	EQUIOS
Inks	Truepress inks for Truepress Jet 520HD CMYK (standard), spot color/protective coat
Resolution	Max. 1,200 x 1,200 dpi
Printing speed	Max. 150 m (492')/min. (with option)*
Printing width	150 to 508 mm (6" to 20")
Media width	165 to 520 mm (6.5" to 20.4")
Media thickness	40 to 250 gsm (64 to 157 gsm for the speed of 150 m/min.)*
Dimensions (W x D x H)	4,070 x 2,370 x 2,200 mm (160.3" x 93.4" x 86.7")
Weight	Approx. 4,050 kg (Approx. 8,910 lb)
Power requirements	Printer Controller: Three phase 200 to 240 V, 30 A / 380 to 415 V, 20 A Heater: Three phase 200 to 240 V, 110 A / 380 to 415 V, 55 A Controller PC: Single phase 100 to 240 V, 2 A Unwinder/Rewinder: Single phase 100 to 200 V, 17 A
Operating environment	Temperature: 18 to 24°C (64.4 to 75.2°F) (no sudden temperature changes) Humidity: 40 to 60% (no condensation)

\* Under SCREEN's conditions

## Specifications of JetInspection (option) for Jet520HD

Barcode reading function	2D barcode: QR, Data Matrix, PDF417 (black 100%) Placement angle: 0, 90, 180, 270 degrees Background: white (The necessary blank area around each code is based on the quiet zone of the code concerned.)
Log	Acquired through the user interface
Decode results	Saves all results and outputs them as a CSV file
Power requirements	PC: Single phase 200 to 240 V AC, 15 A x1 Camera: 24 V DC, 600 W (supplied from printer) (can be installed in the rack for EQUIOS)

Full after-sales service network ensures more reliable system operation, helping to build a stronger production base and greater peace of mind for customers

Real-time maintenance minimizes down time

## TRUST Network Service

TRUST Network Service is a proprietary support program provided by SCREEN to prevent unexpected problems. This program offers a full menu of services including predictive diagnosis based on monitoring equipment conditions, as well as regular analytical and maintenance reports. If trouble does occur, it is also able to precisely identify the area of malfunction.

### TRUST Assist

- Remote maintenance  
(Handling of software, setting parameter, operation errors)
- Analysis of problems, recovery  
(Remote diagnosis of hardware)

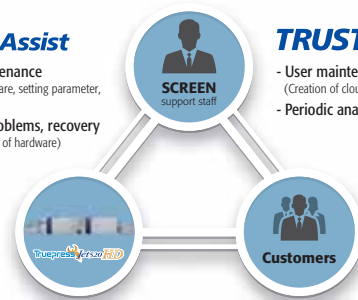

### TRUST Dialog

- User maintenance support  
(Creation of cloud-based client pages)
- Periodic analysis reports

### TRUST Guard

- Proactive maintenance using monitoring and diagnosis of equipment status
- Assessment of replacement timing for periodic replacement parts
- Provision of regular system analysis reports

Contact your local SCREEN representative for detailed information on TRUST Network Service.



# SCREEN Graphic and Precision Solutions Co., Ltd.

## HEAD OFFICE

• Tenjinkita-machi 1-1, Teranouchi-agaru 4-chome, Horikawa-dori, Kamigyo-ku, Kyoto 602-8585, Japan / Tel: +81-75-414-7610

## SCREEN GP Americas, LLC

• 5110 Tollview Drive, Rolling Meadows, IL 60008, U.S.A. / Tel: +1-847-870-7400 / Fax: +1-847-870-0149 www.screenusa.com

## SCREEN GP Europe B.V.

• Bouwerij 46, 1185XX Amstelveen, The Netherlands / Tel: +31-20-456-78-00 / Fax: +31-20-456-78-05 www.screeneuropa.com

## U.K. office

• Tel: +44-1582-72-5400 / Fax: +44-1582-72-5405

## SCREEN HD Singapore PTE. Ltd.

• 29, Kaki Bukit View, Kaki Bukit Techpark II, Singapore 415963 / Tel: +65-67493833 / Fax: +65-67499010 www.screensp.com.sg

## Indian Liaison office

• Tel: +91 22-6673-5088 / Fax: +91 22-6673-5087

## SCREEN GP China Co., Ltd.

• Room 2001 - 2003, 20/F Cable TV Tower 9 Hoi Shing Road Tsuen Wan, N.T. Hong Kong / Tel: +852-2953-0038 / Fax: +852-2755-8683 www.screenchina.com

## Shanghai office

• Tel: +86-21-3126-5122 / Fax: +86-21-5218-2199

## Beijing office

• Tel: +86-10-6708-9271, 9272, 9273 / Fax: +86-10-6708-9395

## Guangzhou office

• Tel: +86-20-3891-1112 / Fax: +86-20-3891-1036

## SCREEN GP Taiwan Co., Ltd.

• 4th Floor, No. 126-1, Min-tsu West Road, Taipei, Taiwan R.O.C. / Tel: +886-2-25862711 / Fax: +886-2-25914367

## SCREEN HD Korea Co., Ltd.

• Vonsel Bongrae B/D 101L, Bongrae-Dong, Joong-Gu, Seoul, 100-161, Korea / Tel: +82-2-727-0860 / Fax: +82-2-727-0876 www.screen-korea.com

## SCREEN GP Australia PTY., Ltd.

• Suite 11, 2 Eidan Park Drive, Macquarie Park, NSW 2133, Australia / Tel: +61-2-9016-3400 / Fax: +61-2-9016-3425 www.screenaustralia.com.au

Internet web site : [www.screen.co.jp/gp](http://www.screen.co.jp/gp)

[www.screenusa.com](http://www.screenusa.com)

[www.screeneuropa.com](http://www.screeneuropa.com)

- This brochure was made using SPEKTA 2 screening.

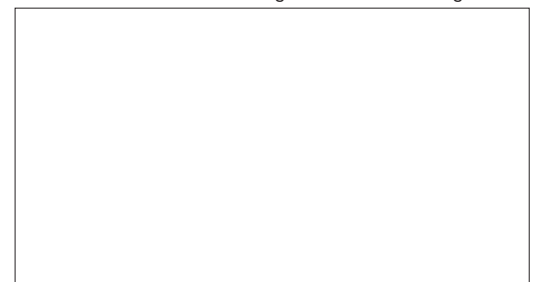

We reserve the right to alter product design and specifications without prior notice.

No.205-162E Printed in Japan 05-16 060PSI(R3-3)